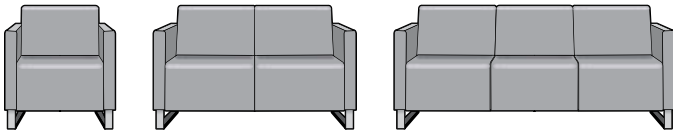

These instructions may be used to disassemble all versions of the Cassia Lounge chair including our single, double and triple versions. We recommend the help of an assistant in disassembling the 2 and 3 seat arrangement.

**Time Required:**

Approximately 15 minutes per chair.

Tools Required:

A 3/8" socket, extension and ratchet, #2 Philips screwdriver; flat blade screwdriver; hammer and knife (preferably a box cutter).

Disassembling the Seat and Back Boxes

A & B: If disassembling a single chair, lay the chair on its side as shown. If you are disassembling a 2 or 3 seat arrangement, use the help of an assistant to tilt the chair forward on its front as shown.

The following instructions are the same for each chair in a 2 and 3 seat arrangement.

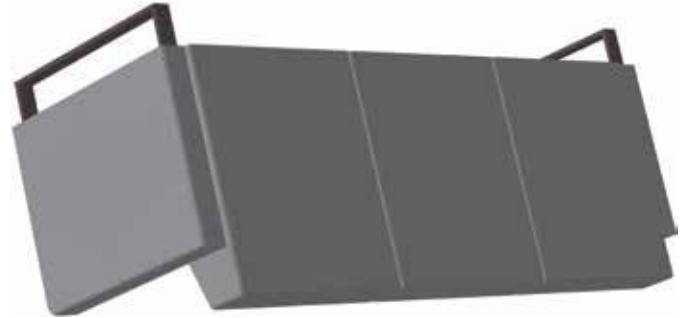

C: Carefully cut away the upholstery from around the brackets attaching the arms to expose the fasteners securing the arms to the seats. Using a 3/8" socket, extension and ratchet, remove the fasteners. Place the arms to one side.

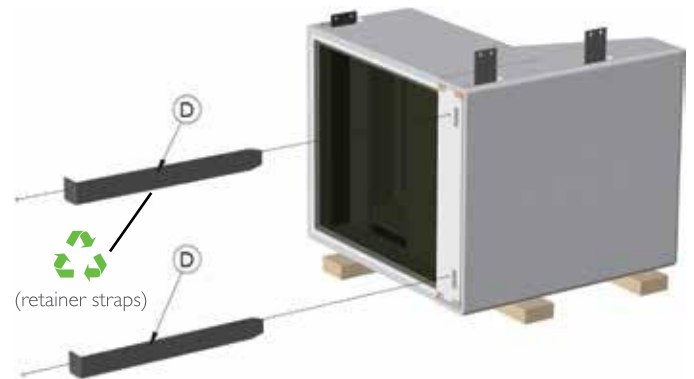

D: If you are disassembling a single chair, it may be easier now to place blocks of wood under the chair so that the seat and back support rails clear the floor. Using the Philips screwdriver, remove the screws from the retainer straps securing the support rails in place. It may require a screwdriver and a hammer to remove the straps, particularly with a 2 or 3 seat arrangement as there will be some binding on the rails if the seat boxes are resting on the floor.

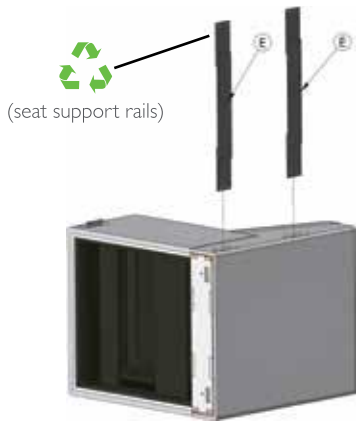

E: Slide out the seat support rails.



F: Now separate the seat box from the back box.

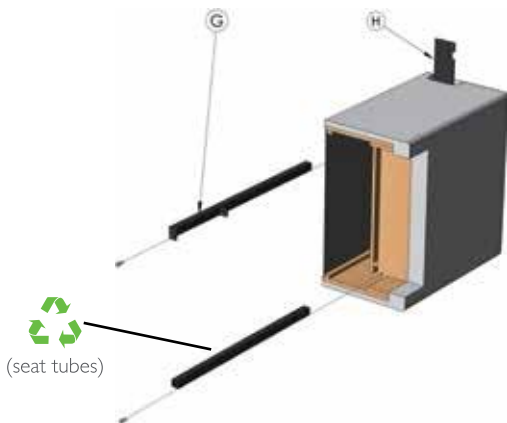

G & H: Using the Philips screwdriver; remove the screw securing the seat tubes to the seat box and slide them out. Next slide out the seat box support rail.

H: Take the knife or box cutter and carefully slice the fabric alongside the staples attaching the fabric to the seat box. Do the same to the back box.

I: Now taking the knife, or preferably a box cutter carefully slice away the foam from the plywood boxes.

Disassembling the Arms

Taking the knife, or preferably a box cutter carefully slice away the foam.

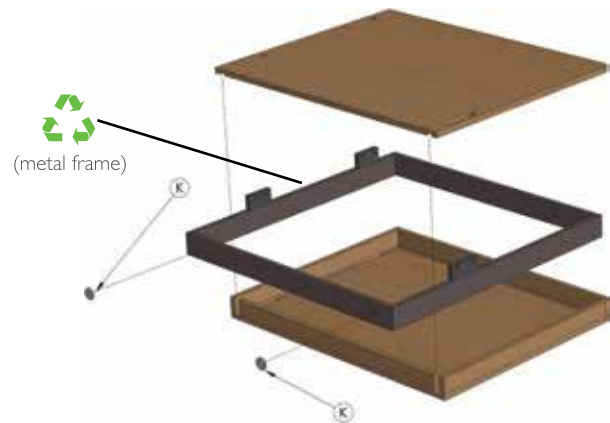

J: As you did with the seat and back boxes, carefully remove the fabric and foam from each arm box. Next taking the flat blade screwdriver and hammer, pry away one side of the arm box. Remove the metal frame from the box. Now remove the glides using the flat blade screwdriver and hammer.

Material Breakdown

Quantity	Component	Material
1	Seat box	Wood
1	Back box	Wood
2	End frame box	Wood
4	Glides	Nylon
2	Upholstery pieces – seat and back	Vinyl, fabric
1	Dust cover	Fabric
2	Seat and back foam	Foam
2	Seat support rails	Steel 
2	Metal frame	Steel 
2	Retainer straps	Steel 
3	Support rails	Steel 
Various	Fasteners and Staples	Steel 